

Versa® TILE T100
User's Guide

Versa® TILE T100 User's Guide

Rev. 1.1, November, 2008

Part #117-0161

Copyright © Element Labs, Inc.

The Element Labs logo, RasterMAPPER™, and Versa® are trademarks of Element Labs, Inc.

Other trademarks and trade names may be used in this document to refer to products by other entities. Element Labs, Inc. claims no proprietary interest in trademarks and trade names owned by others.



Information and specifications in this document are subject to change without notice. Element Labs, Inc. assumes no responsibility or liability for any errors or inaccuracies that may appear in this manual.

Contact Info

World Headquarters	German Office	UK Office
Element Labs, Inc. 9701 Metric Boulevard Suite 200 Austin, TX 78758 United States tel +1 512 491 9111 fax +1 512 491 9122 http://www.elementlabs.com support@elementlabs.com	Element Labs GmbH Lindener Str. 15 D-38300 Wolfenbüttel Germany tel +49 5331 905660 fax +49 5331 905661	Element Labs Ltd. 19A Perseverance Works 38 Kingsland Road London E2 8DD United Kingdom tel +44 (0) 20 7749 0611 fax +44 (0) 20 7749 0622

Safety Information

The symbols below are used throughout this manual to identify important safety information. Heed all warnings and safety information.

Symbol	Meaning
	Warning, Danger, or Caution Risk of injury to yourself or the product.
	Risk of Electrical Shock Risk of severe electrical shock.

	Risk of Electrical Shock. No serviceable parts inside. Observe all local, national electrical and environmental codes.
Warning	The socket-outlet shall be installed near the equipment and shall be easily accessible.

Warranty Information

Element Labs, Inc. warrants Versa TILE T100, a hardware product, against defects in materials and workmanship under normal use for a period of one (1) year from the date of retail purchase by the original end-user purchaser.

Element Labs, Inc. does not warrant that the operation of the product will be uninterrupted or error free. Element Labs Inc. is not responsible for damage arising from failure to follow instructions relating to the product's use.

Federal Communications Commission (FCC Statement)

This equipment has been tested and found to comply with the limits for a class B digital device, pursuant to Part 15 of the FCC rules. These limits are designed to provide reasonable protection against harmful interference when the equipment is operated in a commercial environment.

This equipment generates, uses, and can radiate radio frequency energy and, if not installed and used in accordance with the instruction manual, may cause harmful interference to radio communications. Operation of this equipment in a residential area may cause harmful interference, in which case the user will be responsible for correcting any interference.

Changes

Element Labs provides this manual 'as is' without warranty of any kind, either expressed or implied, including but not limited to the implied warranties or merchantability and fitness for a particular purpose. Element Labs may make improvements and/or changes to the product(s) and/or the program(s) described in this publication at any time without notice.

This publication could contain technical inaccuracies or typographical errors. Changes are periodically made to the information in this publication; these changes are incorporated in new editions of this publication.

Marking

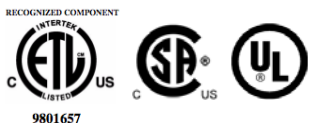

Conforms to ANSI/UL Std. 60950-1
Certified to CAN/CSA Std. C22.2 No. 60950-1

TABLE OF CONTENTS

Chapter 1: Introduction	1-1
System Overview	1-1
Processing Components	1-2
Versa DRIVE D2 Quick Start	1-2
Versa DRIVE C1 Quick Start	1-2
Versa COM	1-3
Recommended Accessories	1-6
Chapter 2: Panel Assembly and Mechanical	2-1
Overview	2-1
System Configuration	2-2
Basic Nine-Panel System	2-3
Basic Nine-Panel Column	2-4
Irregular TILE T100 configuration	2-5
Chapter 3: Parts and Options	3-1
Standard Plastic Bracket	3-1
Center Mount System	3-3

INTRODUCTION

This User's Guide covers the typical Versa® TILE T100 system and its various components in detail and illustrates sample configurations.

Chapters in this manual are divided into the following topics:

- [Introduction](#), (p. 1-1)
- [Panel Assembly and Mechanical](#), (p. 2-1)
- [Parts and Options](#), (p. 3-1)

System Overview

A Versa TILE T100 system is composed of TILE T100 panels, Versa COM local power and data distribution hubs, and Versa DRIVE processors. The system can be configured for a wide variety of applications. The panels can be used as part of a continuous cladding system or individual panels can be deployed on multiple planes as part of a complex three-dimensional array.

A TILE T100 system is lightweight and integrates multiple attachment points. A system can be installed with hardware supplied by Element Labs or using components readily available at the local hardware store.

A system is configured in the Element Labs RasterMAPPER utility and then loaded onto a Versa DRIVE. As with all Versa products TILE T100 can be placed in a map with other Versa products as part of a single system.

The control system accepts a standard DVI signal from a computer or video processor capable of outputting a XGA (1024 x 768) video signal. The system is completely X,Y accurate within this window and multiple sources can be used to create systems which extend beyond a single XGA work space.

Addressing, data distribution, and, power distribution, are handled by the Versa COM. The Versa COM incorporates a power supply and an addressing board.

Processing Components

Quick start guides for the Versa DRIVE series processors are included in this manual. Additional information can be found on the Element Labs web site on the Support Page (<http://www.elementlabs.com/support>).

Versa DRIVE D2 Quick Start

NOTE The D2 must be OFF when plugging or unplugging any DVI connections. Failure to do so may damage equipment.

1. With the D2 and computer OFF, connect the DVI output of the computer to the input of the D2. Connect a loop-thru monitor to the output of the D2 if you need one.
2. Connect the AC power cable to the D2.
3. Connect the serial RS232 from your computer to the D2.
4. Connect the serial output(s) of the D2 to TILE T100, TUBES, PIXELS, or RAYS.
5. Turn on the Versa DRIVE D2, allow it to boot.
6. Turn on the computer, allow the computer to begin to start up.
7. Turn on the loop-thru monitor if you have one. It is important to turn your local computer monitor on last so the DVI chain will ID correctly. If you are using a DVI Detective ignore this advice.
8. Press the menu button from the D2 front panel and enter the input menu.
Verify the following settings:
 - SERIAL = RS232
 - ID = 1
 - V-SYNC = HIGH/PC (for connection to computer)
 - or
 - V-SYNC = LOW (for connection to Folsom Scan Converter)
9. Verify that the DVI output is recognizing a display and is set to 1024x768 @ 60hz.
10. Verify that the D2 recognizes the DVI signal by setting the display mode to video from the display mode menu and watching for a steadily blinking DVI light on the front panel.
11. Open RasterMAPPER and connect to the D2 under the Versa DRIVE Control tab.
12. Create a map of your system in RasterMAPPER™ and send a map to the Versa DRIVE D2.
13. The Versa DRIVE D2 will now display the video information arriving at its DVI port on the configured installation.

Versa DRIVE C1 Quick Start

1. Connect Power & Data Cables. Use the Local or Serial Data output to connect to your TILE T100 or TUBE system.
2. Create a map of your system in RasterMAPPER.
3. Import .AVI videos or .BMP still images into RasterMAPPER to create patterns.
4. Output the patterns as .CFF files and store them on a Compact Flash (CF) card.
5. Insert the CF card into the C1 and turn the power on.

6. Use the MODE, UP (^), and DOWN (V) buttons to select different patterns and playback modes.

DMX functionality using the Versa DRIVE C1 is explained in the manual.

Versa COM

The Versa COM takes serial data and 100 volt – 250 volt AC power and converts these to local data and 12 volt DC power for distribution to the TILE T100 panels.

The Versa COM is available in installation and rental configurations.

The installation configuration of the Versa COM is designed to permanently tie into an existing building electrical system according to the local electrical code in force on the installation site. The AC is attached via a terminal connection and the data is connected using an RJ45 connector for both the input and the output.

The rental configuration features a Neutrik ProCon connector for power and a 6 pin XLR connector for data.

The Versa COM features an LCD display and three buttons.

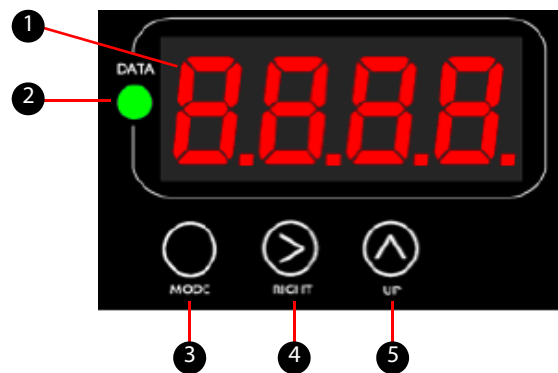

1 Digital Display

Displays the modes and parameter values.

2 Data Indicator

LED Blinking rapidly – RS 422 data input is OK.

Steady ON or OFF – RS 422 data input is missing or corrupt.

3 MODE Button

Cycles through several operational modes.

4 RIGHT (>) Button

Used to enter into a mode and step through the adjustable parameters.

5 UP (^) Button

Used to step up through the parameter values.

The MODE button on the Versa COM menu cycles through the following seven functions:

1. *ADDR* (Address) sets the starting pixel address of the panel
2. *SIZE* (Size) sets the number of pixels for that panel
3. *NEXT* (Next) displays the start address of the following pixel
4. *DISP* (Display) turns the digital display and the Data LED off or on
5. *F-BB* (Firmware) displays the Versa COM firmware version
6. *TYPE* (Type) sets the Versa DRIVE type
7. *LDC* (Lock) locks the boards RIGHT and UP buttons

Several modes (Address, Size, and Type) have values that can be set by the user as follows:

1. Press the MODE button to cycle through the modes.
2. Press the RIGHT (>) button to select the first (or next) digit when the desired mode is shown in the display. The selected digit will be flashing.
3. Press the UP (^) button to increment the value of the selected digit.
4. Repeat steps to set all of the digits.
5. Press the MODE button to exit the current mode. Any changes will be automatically saved.
6. The Versa COM automatically locks after 10 seconds. This disables the RIGHT (>) and UP (^) buttons. Press the MODE button to unlock the Versa COM.

Setting the Address, Size, and Type

1. Set the starting pixel address (Addr mode). The starting pixel address of the first panel (fixture #0 in the RasterMAPPER map) should be number 1. The starting address for the other Versa COM units will need to be calculated (also, see the *NEXT* function below).
2. Set the size (SIZE mode). The size is the total number of pixels for all fixtures on that Versa COM. For example, 5 TILE T100 T100 panels would be 80 pixels (5x16).
3. Set the Versa DRIVE type that is being used with the system (TYPE mode).
4. Also, when the Versa COM is locked the display will alternate between the first panel's address in that Versa COM and the first panel's address in the next Versa COM. This is convenient for automatically calculating the starting address on a series of Versa COM units where each unit is driving the same number of panels.

Display Function

The LED display and data light can be turned off if they are distracting. This will not affect the normal operation of the Versa COM.

1. Press the MODE button to get to the *DISP* mode.
2. Press the RIGHT (>) button to show the current display mode – either “on” or “off”.
3. Press the UP (^) button to change the value between on and off.

The display will not immediately turn off. The display will turn off whenever the Versa COM goes into Lock mode automatically. If you manually lock the Versa COM, the display will stay active for 10 seconds, then black out. When the display is off, pressing the MODE button will automatically turn it back on.

NOTE When the display is off the Versa COM panel looks the same as if it is turned off. Keep this in mind when troubleshooting.

Firmware Version

The firmware mode displays the current firmware version in the format F - ## where ## is the version number. The RIGHT (>) and UP (^) buttons have no function in this mode.

Lock Mode

The Versa COM automatically locks after 10 seconds. This disables the RIGHT (>) and UP (^) buttons. Press the MODE button to unlock the Versa COM.

You can also manually lock the Versa COM by selecting the Lock mode with the MODE button and the pressing the RIGHT (>) button. When the Versa COM is locked the digital display shows all four decimal points on. When the Versa COM is locked, the display alternates between the current address value and the next address value (as determined by address + size values).

Data LED

The green Data LED will flash rapidly when there is valid Serial Data coming into the Versa COM. If the LED is either on (not flashing) or off, then there is not valid Serial Data on the data input of the Versa COM.

Recommended Accessories

DVI video monitor

In order to be able to monitor the video feed being sent to the D2, a true DVI video monitor is recommended.

NOTE A native 1024x768 monitor is recommended as this is the resolution of the D2 processor, but any DVI monitor will work. Once again note that DVI to VGA adapters will not work for this purpose.

Geffen DVI Detective

This small adapter goes in between the computer DVI output and the processor. The adapter will send a constant ID to the computer, telling it to send a DVI signal. This means that processors and monitors after it can be unplugged, added, turned off, reset etc. without the computer seeing it and attempting to re-configure the video output settings. This is also helpful for driving DVI signal extenders such as a DVI over Fiber connection. DVI detectives are available through Element Labs, directly from Geffen, or through many online retailers.

NOTE The Geffen DVI Detective can alleviate many problems with configuring DVI outputs especially when using media server software.

PANEL ASSEMBLY AND MECHANICAL

Overview

A TILE T100 panel is a 40 cm x 40 cm square. The TILE T100 Universal Back Panel [UBP] has been designed to accommodate a number of mounting options.

There are 16 M4 attachment points on the back of the UBP which can be used to attach to any number of off the shelf mounting systems.

There are four corner mounting holes located 50 mm x 50 mm off the corners of the UHB (top holes indicated).

There are four center mounting holes located in a 100 mm x 100 mm square at the center of the UHB.

There are eight utility mounting holes located down the right and left side of the UHB (right holes indicated).

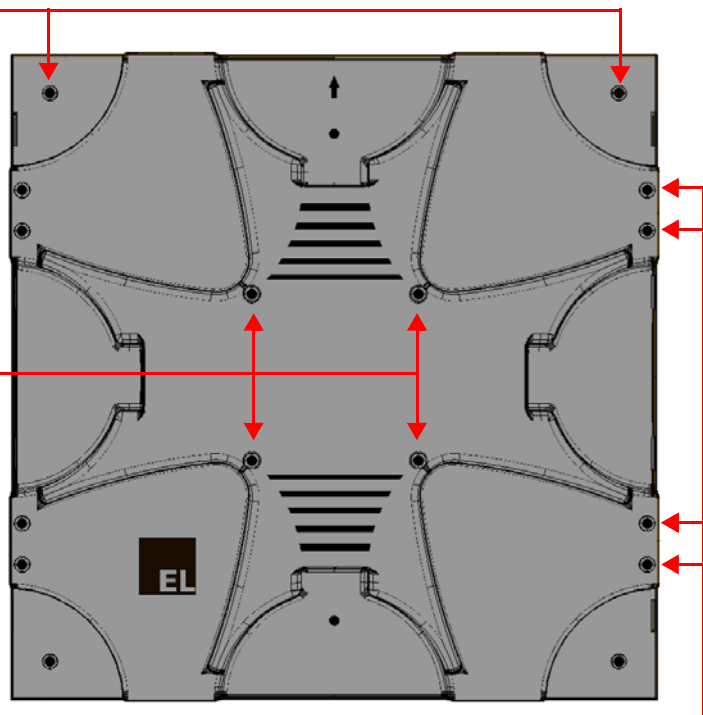

System Configuration

The following figure illustrates a sample Versa TILE T100 configuration.

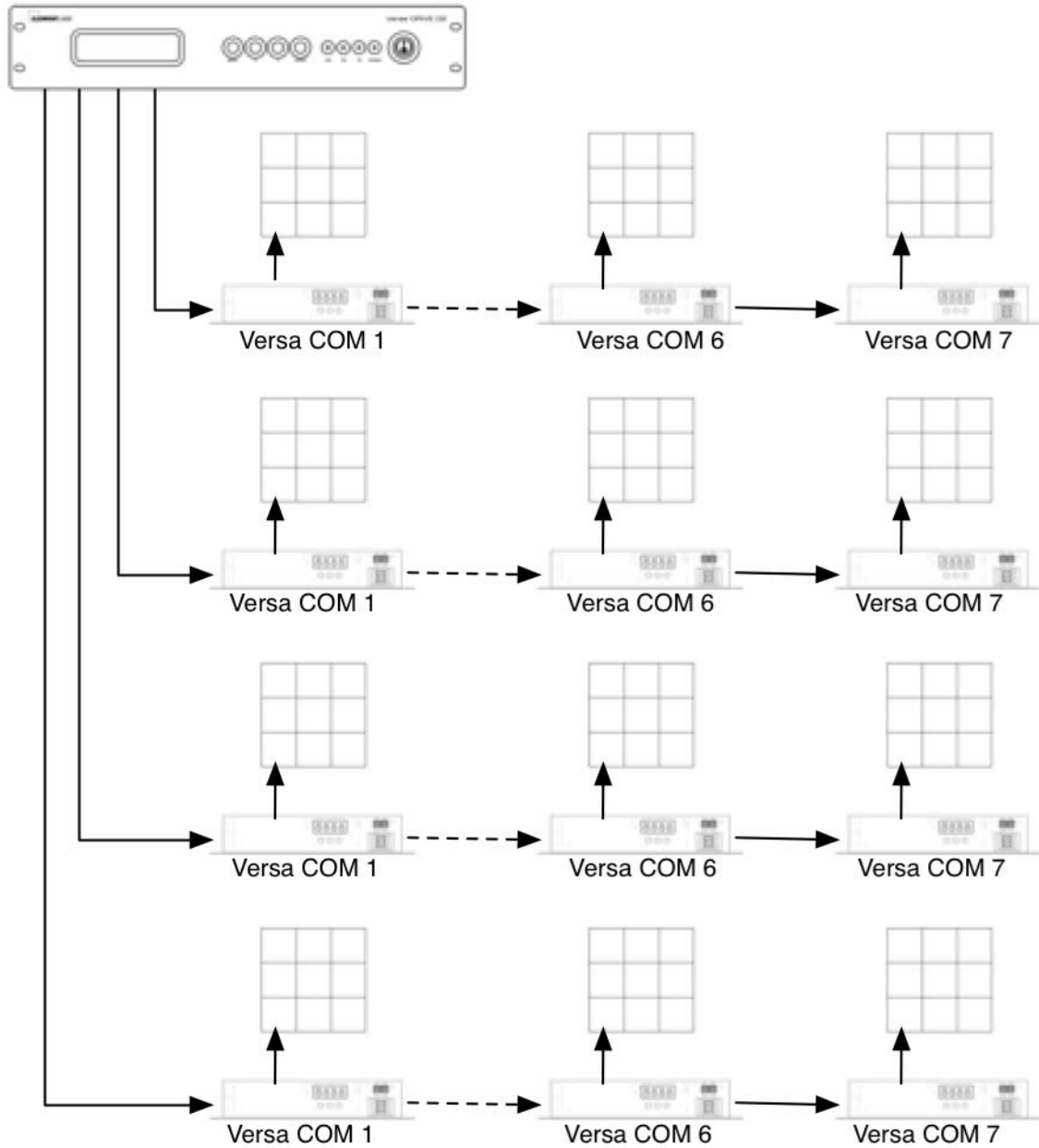

Basic Nine-Panel System

Nine TILE T100 T100 panels can be connected to a single Versa COM box in a 3 x 3 grid. Multiple Versa COM units can be daisy chained together and a large array can be configured in this manner.

Local Data loops from panel to panel through the nine panels that can be driver off a single Versa COM.

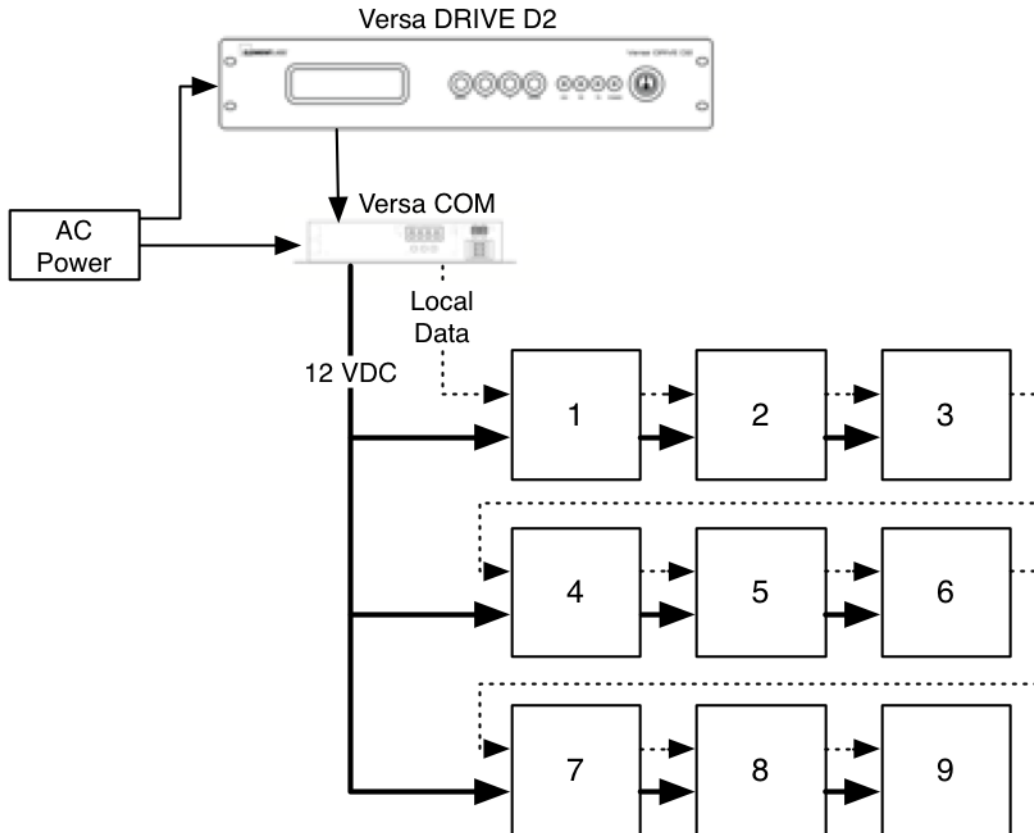

Basic Nine-Panel Column

Nine TILE T100 T100 Panels can be connected to a single Versa COM box in a column. Multiple Versa COM units can be daisy chained together and a large array can be configured in this manner. In this way the Versa COM units can be placed at the top and bottom of a wall of TILE T100 T100 panels 7.2 meters (23.4 feet) tall. This leaves the center of the wall free of power supplies or data distribution.

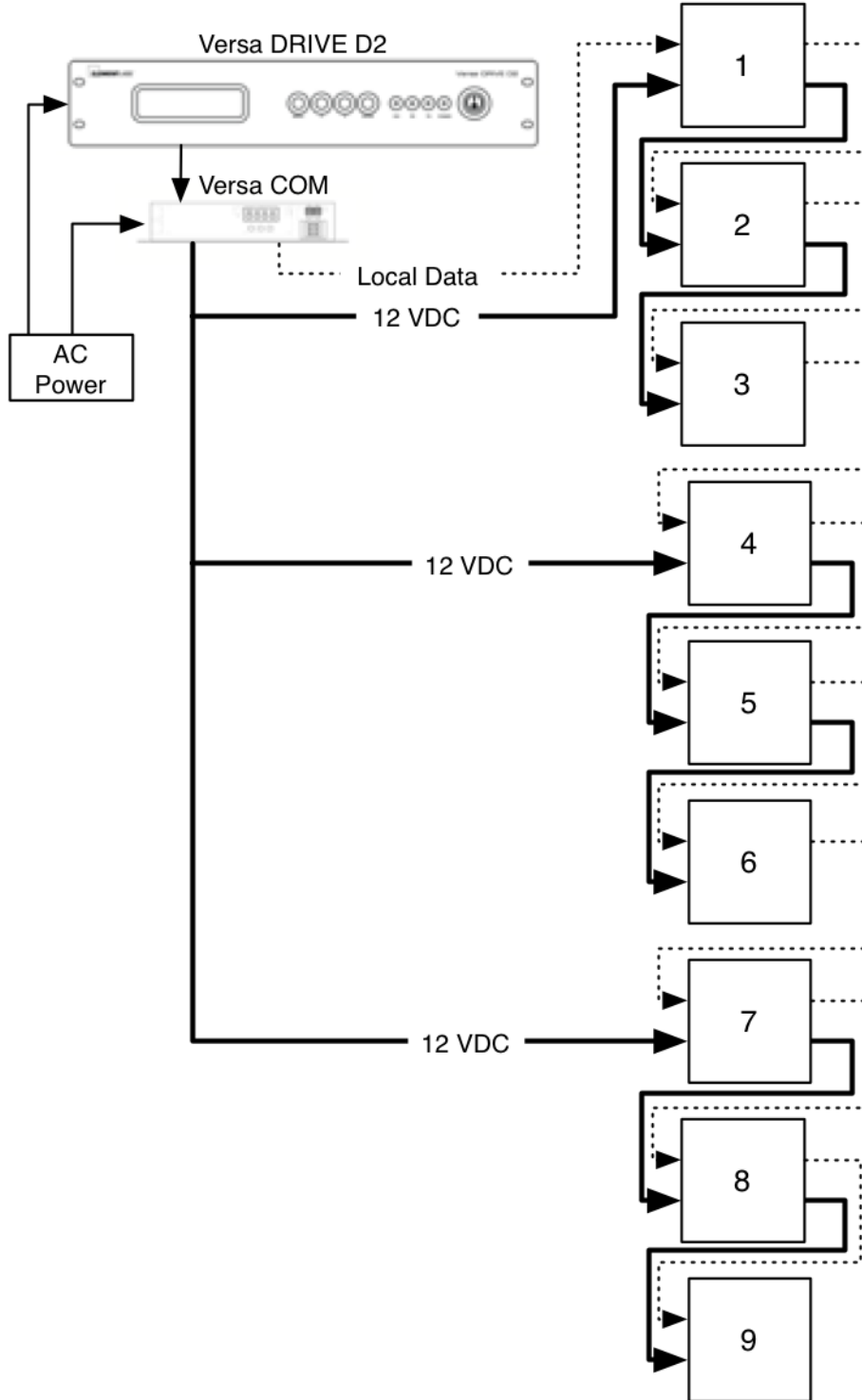

Irregular TILE T100 configuration

The mechanical options available for configuring TILE T100 allow for irregular panel configurations. In these systems the Local Data distribution needs to be coordinated with the layout of the system in RasterMAPPER in order to allow for the shortest cable runs.

Long cable runs may limit the number of panels that can be run off a single Versa COM. Since every system is different Element Labs recommends testing any irregular design before a system is installed. If testing is not possible allow for extra Versa COM units on site during the install.

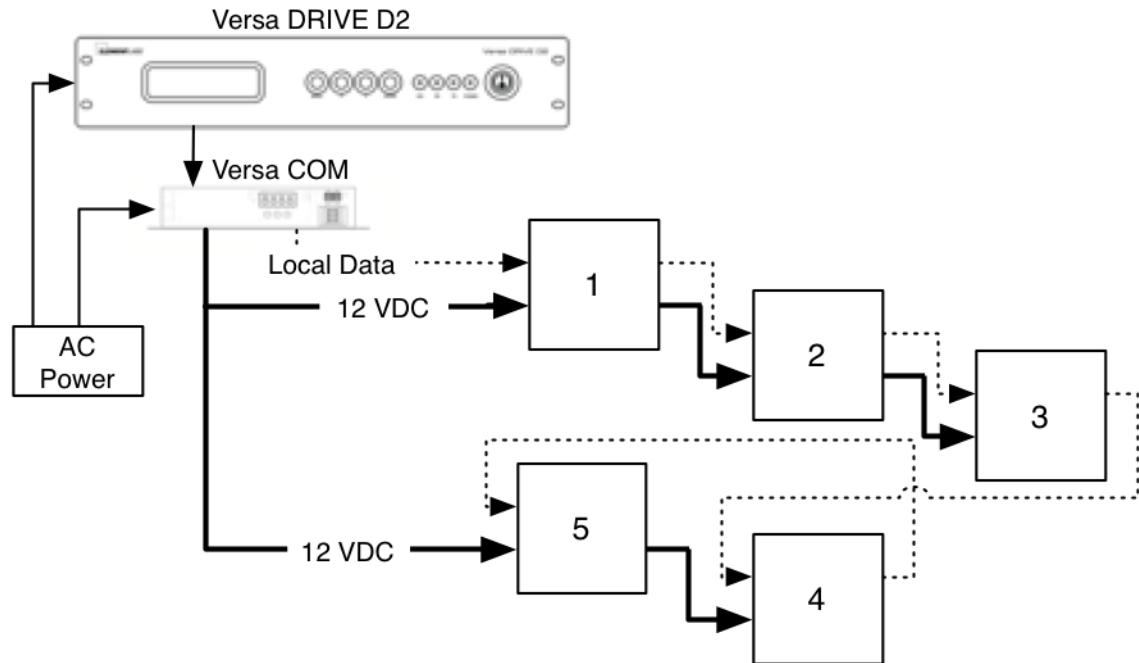

PARTS AND OPTIONS

TILE T100 M4 Screws

The TILE T100 Universal Back Panel (UBP) has is designed to work with M4 metric screws. These screws can be used with all Element Labs provided metal brackets. Screws are provided with each panel and as part of bracket kits but additional screws may be purchased.

TILE T100 Corner Mount System

A corner bracket system designed to work with Unistrut, Octonorm, or 8020 extrusions. The corner brackets also work when screwed into wood or fastened to any other secure mounting surface. Plastic screws go into the four corner locations in the back of the TILE T100 UBP. This forms a 50 mm x 50 mm hole pattern. These M4 screws then slot into the mounting bracket. The wall is built from the bottom up.

Standard Plastic Bracket

The plastic corner bracket is designed to screw into a wall using standard #8 construction screws. When a corner or an edge is required the bracket can be snapped in half or in quarters.

When going up against drywall or concrete a strip of plywood can be used to provide a surface to attach the brackets.

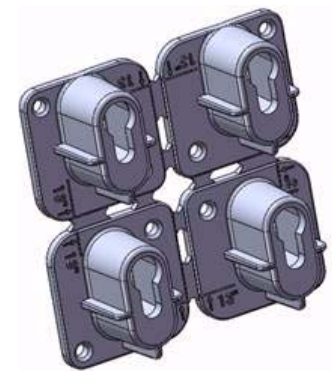

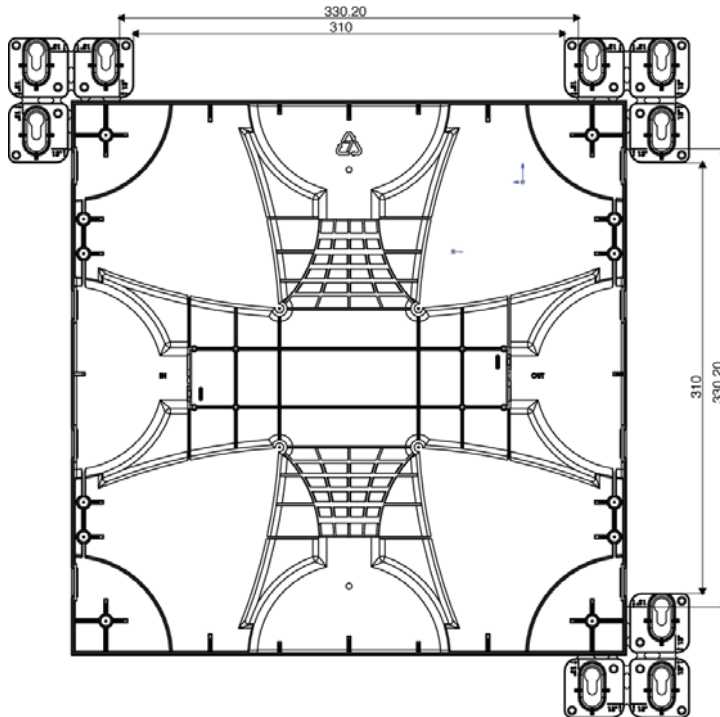
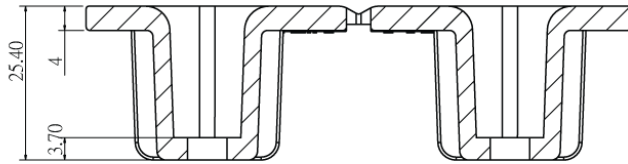
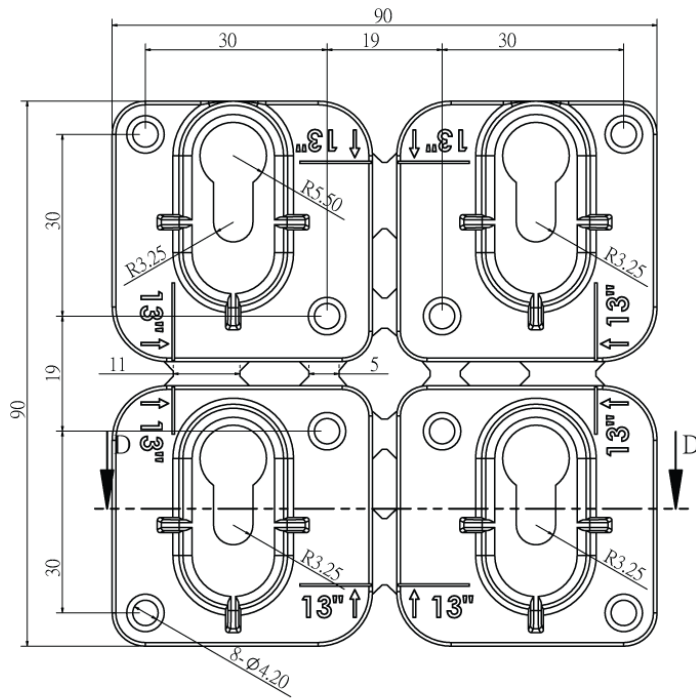

Center Mount System

The hole pattern on the center mount location on the TILE T100 Universal Back Panel is 100 mm x 100 mm square and conforms to off the shelf mounting solutions.

The same M4 screws are used as in the corner mount. In this case the four screws go in the raised center mount location. The mount is attached to a structure and then the panel is slid onto the mount.

The half-inch hole in the center of the mount is compatible with a standard half cheeseborough or a theatrical C-clamp.

